

MODEL 660

TOP MOUNT DRIVE

VARIABLE PRESSURE ACCUMULATION CONVEYOR

Industrial conveyor designed for applications where dwell stations or safe accumulation of product is needed. Allows a changeable combination of totally free moving and controlled-accumulation sections. Uses an externally adjustable bolt to quickly adjust spring-loaded pressure roller brackets anywhere from full driving force to zero.

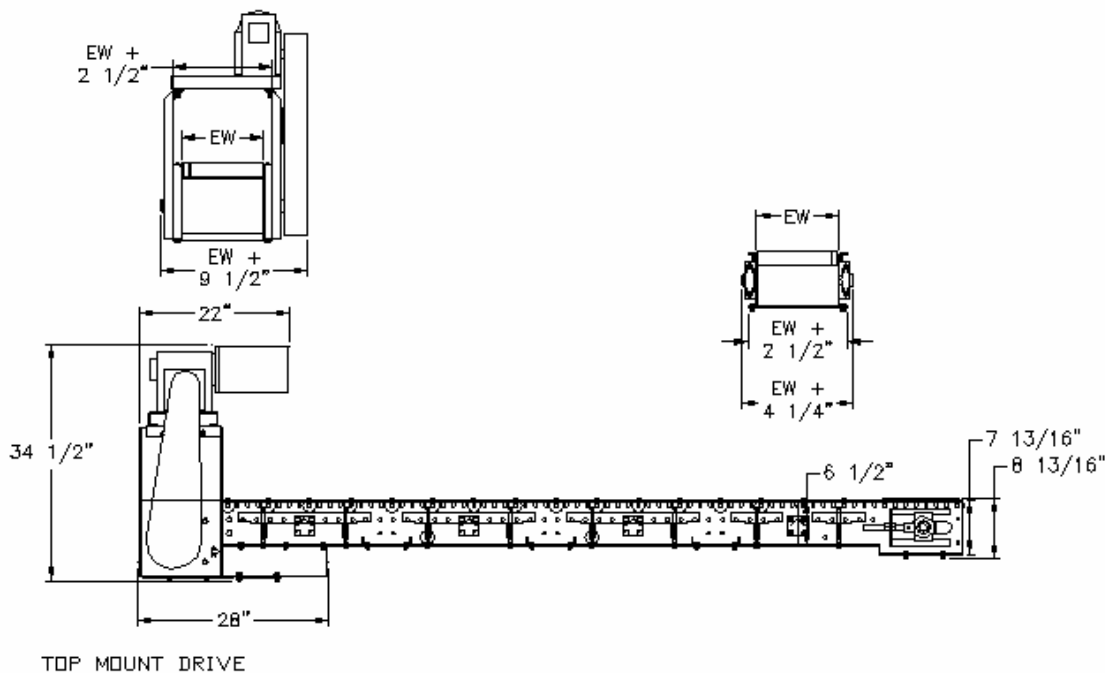

TOP MOUNT DRIVE

1700 Division Street, New London, WI 54961

Phone: (800) 437-1994

Fax: (920) 982-6800

www.nleco.com